

AUTO AMPLIFIER CHANGEOVER

6 DUTY / 1 STANDBY AUTO AMPLIFIER CHANGEOVER PANEL | AX3700



Amperes AX3700 offers a great flexibility and simplicity in cabling for auto amplifier fault changeover system with its combination of amplifier fault sensor modules and changeover panel in a box. The internally generated Pilot Tone and sensory circuit shall detect any faulty duty amplifier and would initiate a changeover process.

AX3700 has been optimised for faster fault detection and changeover as compared with AS4000 modules. Pilot tones are generated at intervals to avoid constant loading of power amplifiers.

Changeover are performed at both input and output sections, making it suitable for application in a matrix system. At any one time, only a failed duty unit shall be replaced by a standby amp, to avoid overloading.

FEATURES -

- Cater for 6 duty and 1 standby
- Expandable for 1 standby to cater for more than 6 duty amps.
- Built in Pilot Tone generator, transmit at intervals and senses at sequence to protect amplifiers
- Overloading protection by allowing only a single take over
- Prioritised changeover which higher numbered amplifier shall be preferred for take over if more than two units are down
- Shorter fault detection time from 10 to 25 seconds
- Changeover at input and output section simultaneously ; suitable for matrix system installations
- Input link switch ; making connection of sources easier
- Channel isolation switch for unused or un-monitored channel
- Individual channel status indicators ; normal, fault and changeover

TECHNICAL SPECIFICATIONS -

Operating voltage	24V DC 1A via PS9400 PSU
Power consumption	7.2W
Input signal	6 ch. balanced line signal
Input impedance	10 K Ohm
Audio output gain	Unity
Pilot tone interval	10 secs / channel
Pilot tone frequency	20 KHz (+/- 5%)
Detection line	70 / 100V line
Detection level	50V rms
Failure detection time	10 ~ 25 seconds
Failure recovery time	20 seconds max
Zone load rating	400W / 100V line
Status indications	Normal ; Fault ; Changeover
Changeover alert	Buzzer with switch
Changeover section	Input and Output simultaneously
Dimensions (WxHxD)	482 x 88 x 180 mm
Weight	2.8 kg

Rear View

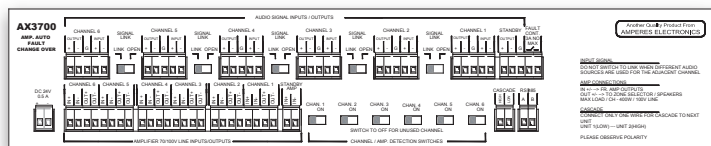

APPLICATION SCHEMATIC -

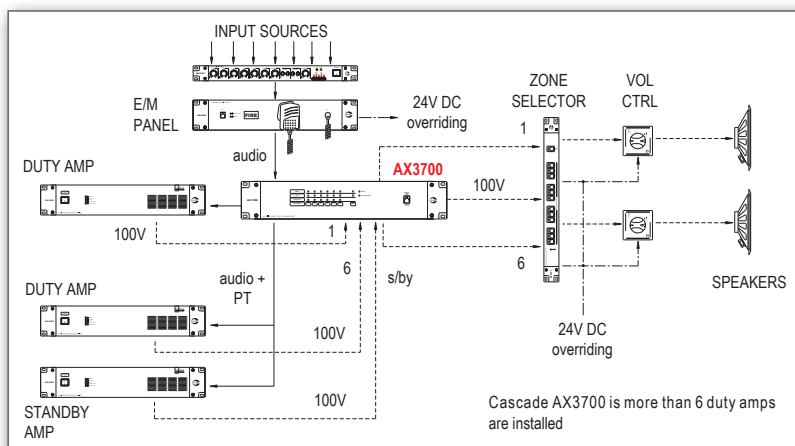

Packing information

- Carton : 552 (W) x 163 (H) x 294 (D) mm
- Weight : 3.6 kg
- Qty : 1 units / carton