

MANUAL AMPLIFIER CHANGEOVER

6 DUTY / 1 STANDBY AMPLIFIER CHANGEOVER PANEL | **AC3601**



Amperes AC3601 is a manual changeover panel for 6 duty with 1 standby amplifier and is required for a standby unit to take over a failed duty amp to ensure uninterrupted and continuous operation of a PA system. More than one AC3601 can be cascaded for a single standby unit to cater for more than 6 duty packs.

Protection circuitry is embedded that only allows one failed duty amplifier to be taken over by standby unit to prevent overloading. Priority features shall ensure higher numbered failed unit has preference for changeover.

APPLICATION SCHEMATIC -

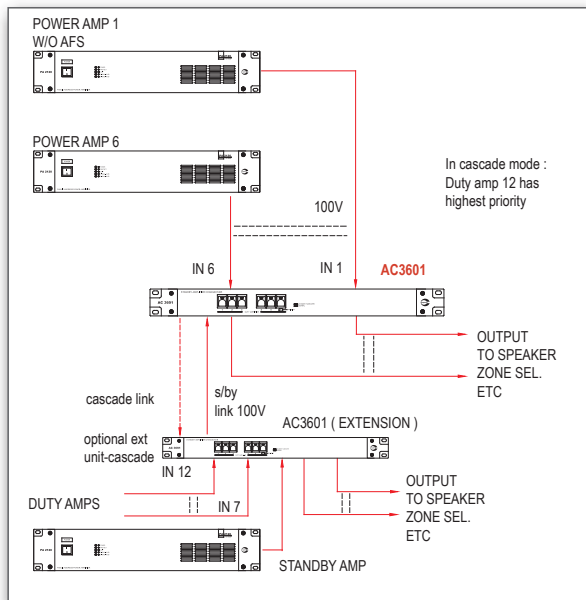

FEATURES -

- Cater for 6 duty and 1 standby amplifier
- Expandable for 1 standby to serve more than 6 duty units
- Overload protection by allowing only a single take over
- Prioritized changeover - unit with higher number is preferred for changeover
- Manual front panel changeover selection

TECHNICAL SPECIFICATIONS -

Operating voltage	24V DC via PS9400 PSU
Power consumption	Standby : 82 mW, 3.4 A Operating : 1.3 W, 50 mA
Zone load rating	400W / 100V line per ch.
Amplifier inputs	6 duty / 1 standby
Changeover indication	Front switch LED
Switching mode	Via front panel switch
Cable connection	Plug in connectors
Cable size	2.5 mm sq
Dimensions (WxHxD)	482 x 44 x 180 mm
Weight	2.0 kg

Rear View

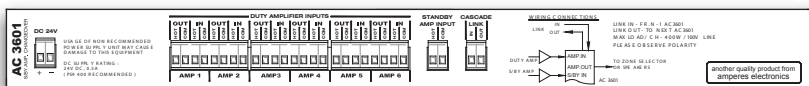

Packing information

- Carton : 552 (W) x 93 (H) x 294 (D) mm
- Weight : 2.6 kg
- Qty : 1 units / carton