

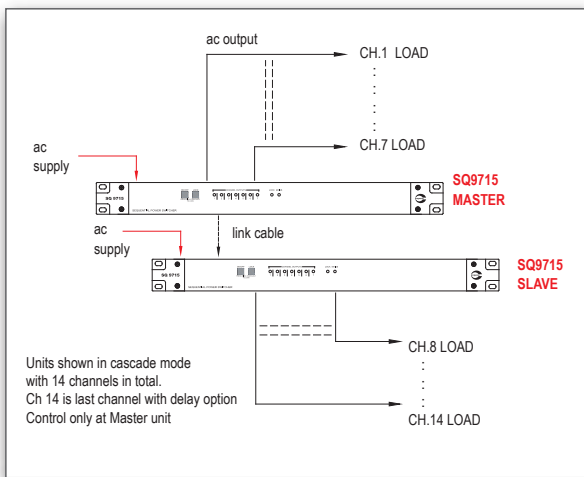

When rules of switching On or Off the stack of AV or PA equipments are neglected, it may cause damage to the component of the system, such as speakers, amplifiers or video projectors.

SQ9715 offers a solution to the switching sequence by switching on in sequence from channel 1 to 7 and vice versa during shutting down by a push of a switch. Two units of SQ9715 can be linked to form 14 channels setup ; one being Master and the other as Slave.

APPLICATION SCHEMATIC -



Rear View

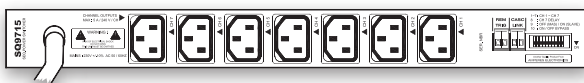

Packing information

Carton : 552 (W) x 93 (H) x 294 (D) mm
 Weight : 3.3 kg
 Qty : 1 units / carton

FEATURES -

- 7 channel with 6A per channel ; total load 15A maximum
- Cascade two units to form 14 channel setup
- Incremental switching from Ch. 1 to 7 (or Ch. 1 to 14 in cascade mode)
- Decremental switching from Ch. 7 to 1 (or Ch. 14 to 1 in cascade mode)
- Remote switching port via external noiseless contact
- AC output via IEC connectors
- Channel isolation via DIP switch
- Ch. 7 with delay Off option for 2 min ; suitable for video projector powering
- Lock mode to avoid incidental switching
- Built in surge protection

TECHNICAL SPECIFICATIONS -

Operating voltage	230 / 240V ac
Power consumption	50 mW (without load)
Output voltage	230 / 240V ac
Max load / channel	6A
Max total load	15A
Output connection	IEC female socket
Max cascade	2 uts : total 14 channels
Surge protection	L-N, L-E, N-E.
Clamping voltage	870V ac
Turn on sequence	Step 1 to 7 incremental
Turn off sequence	Step 7 to 1 decremental
Step timing	2 seconds
Delay off option	Channel 7 via DIP switch
Delay off timer	2 minutes
Switch lock	Via front switch
Indicators	AC mains, Ch. on, Lock
Dimensions (WxHxD)	482 x 44 x 180 mm
Weight	2.7 kg excl. accessories