

Introduction

VP7810 is normally used in hotel room, which is used to override the speaker audio inside bathroom / foyer (BGM ted from TV or other audio player), to central paging audio.

It operates only doing emergency cases, which the central PA is required to send audio to the speaker with 8 Ohm impedance. ie. VP7810's function in to match the impedance of the said speaker.

Features:

- Suitable for 4 wire system : 2 x audio, 2 x 24V DC overriding
- Built in overriding relay for emergency bypass with LED indicator
- Also available with 70 x 120 mm front panel



Technical Specification:

	VP7810
Power rating	10W 8 Ohm
Overriding voltage	24V DC
Patch connection	Hardwired
Cablings	4 wire system
Size (front panel)	86 x 86 x 40 mm 70 x 120 mm face plate available upon request
Weight (excl. enclosure)	215 gms
Back enclosure (optional items)	
Concealed (W x H x D)	77 x 77 x 60 mm
Surface (W x H x D)	85 x 85 x 60 mm

Amperes Electronics reserves the rights to change the above specifications without prior notice. All rights reserved.

Application Schematic:

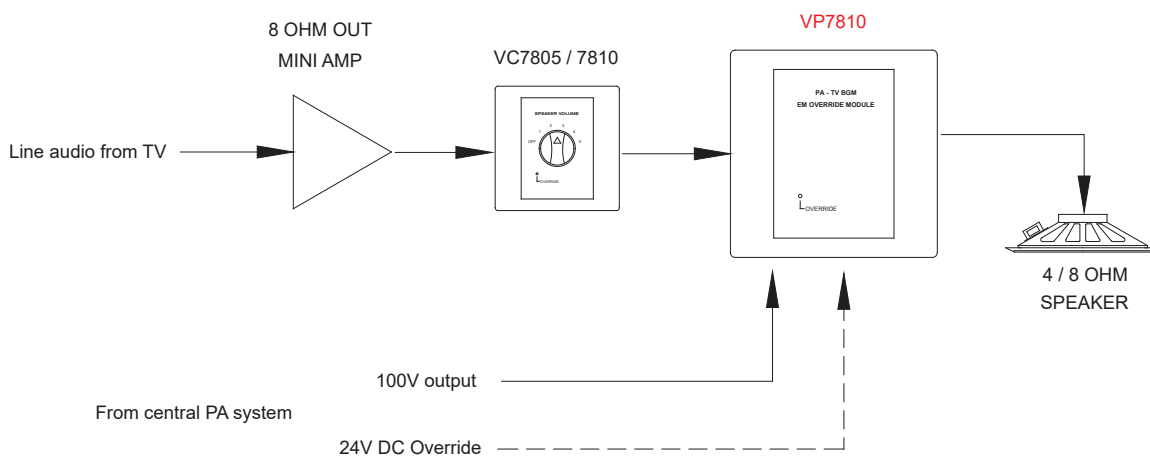

VP7810 application schematic

Installation Guide:

1 : Cable Connection

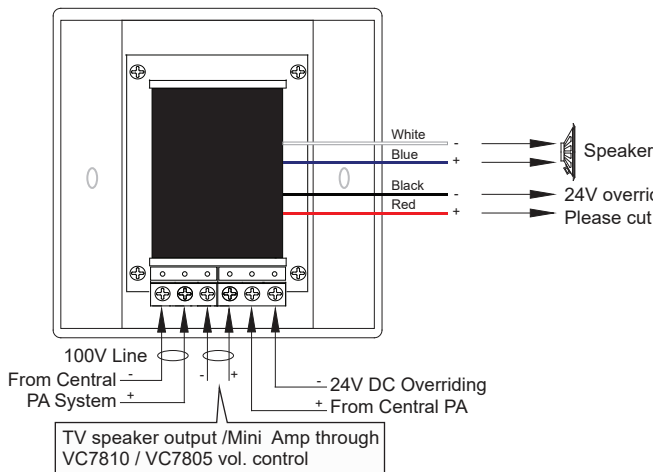

Terminate the incoming cables for Amplifier 100V, TV speaker out and DC overriding signal to the terminal. Output cable to 8 Ohm speaker are Blue and White.

24V overriding cable to loop to next unit if required.
Please cut these cable and insulate them if not used.

2 : Install VP7810 to Back Enclosure

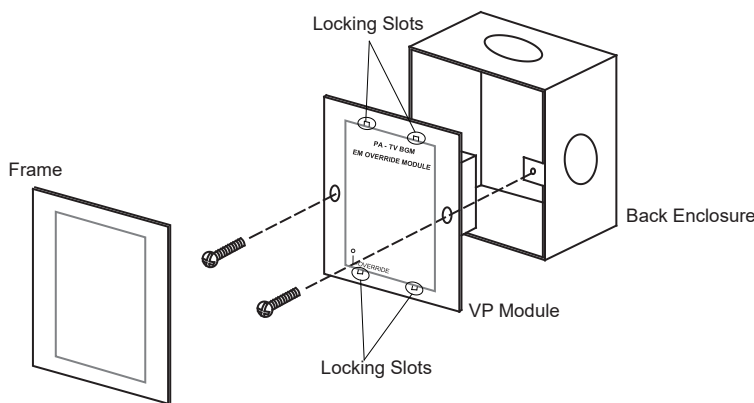

Mount the VP module to back enclosure (surface / conceal), thereafter clip the frame to the back as shown.

Warranty Conditions

Only Amperes Electronics Service Centres are allowed to make warranty repairs : a list of Amperes Electronics Service Centres may be asked for by the purchaser or send directly to Amperes Electronics Sdn Bhd at 70 Jalan Industri PBP 3, Tmn Perindustrian Pusat Bandar Puchong, 47100, Puchong, Selangor, Malaysia or its authorized dealers. This warranty is not valid if repairs are performed by unauthorized personnel or service centres.

This warranty covers only repairs and replacement of defective parts ; cost and risks of transportation as well as removal and installation of the product from the main system are for the account of the purchaser. This warranty shall not extend to the replacement of the unit.

This warranty does not cover damages caused by misuse, neglect, accident of the product as well as using the product with power supply voltage other than shown on the product, or any other power supply source / adaptor not recommended by the manufacturer.

This warranty does not cover damages caused by fire, earthquakes, floods, lightning and every cause not directly related to the unit.

This warranty does not include any indemnity in favor of the purchaser or the dealer for the period out of use of the unit; moreover the warranty does not cover any damages which may be caused to people and things when using the product.

This warranty certificate is valid only for the described product, and is not valid if modifications are made on this certificate or on the identification label applied on the product.

This warranty covers all the material and manufacturing defects and is valid for a period of 36 months from the date of purchase or for a specified period in countries where this is stated by a national law. In this case, the extension is valid only in the country where the product is purchased.

Amperes Electronics Sdn Bhd is not obliged to modify previously manufactured products under warranty if the design changes or improvements are made.

Disclaimer

Information contained in this manual is subject to change without prior notice and does not represent a commitment on the part of the vendor. AMPERES ELECTRONICS SDN BHD shall not be liable for any loss or damages whatsoever arising from the use of information or any error contained in this manual.

It is recommended that all services and repairs on this product be carried out by AMPERES ELECTRONICS SDN BHD or its authorized service agents.

AMPERES series must only be used for the purpose they were intended by the manufacturer and in conjunction with this operating manual.

AMPERES ELECTRONICS SDN BHD cannot accept any liability whatsoever for any loss or damages caused by service, maintenance or repair by unauthorized personnel, or by use other than that intended by the manufacturer.



ISO 9001:2015
Design & Manufacture of Public Address Equipment and Systems
Certificate No. 16895 / A / 0001 / UK / En